

SNAP Analog Output Modules

Features

- Resolution = 0.004% of nominal range
- Rugged packaging
- Convenient pluggable wiring
- Powered by a single 5-volt supply
- Factory calibrated; no user adjustment necessary
- Out-of-range indication
- Operating temperature 0 °C to 70 °C
- Accepts up to 14 AWG wire

Description

SNAP I/O analog output modules are part of Opto 22's SNAP PAC System. They mount on SNAP PAC racks along with other I/O modules and a SNAP PAC brain or R-series controller.

These software-configurable output modules handle a wide variety of signal levels. Most provide dual-channel packaging. All SNAP analog modules are factory calibrated. Part numbers ending in -FM are Factory Mutual approved.

SNAP analog output modules have an on-board microprocessor to provide module-level intelligence, which makes them an ideal choice for Original Equipment Manufacturers (OEMs). For additional information about the stand-alone operation of SNAP analog modules, please refer to the *SNAP I/O Module Integration Guide* (Opto 22 form #876).

For specifications and wiring diagrams, see the module descriptions starting on [page 2](#). Dimensional drawings begin on [page 10](#).

Notes for legacy hardware: SNAP analog output modules can also be used with legacy SNAP Simple, SNAP Ethernet, and SNAP Ultimate brains and with serial SNAP brains such as the B3000. These modules can be mounted on SNAP B-series or M-series racks.

Isolation

All SNAP analog output modules are transformer isolated as well as optically isolated from all other modules and from the I/O processor (SNAP PAC brain or on-the-rack controller). On most dual-channel modules, the two channels are *not* isolated from each other. The exceptions are the SNAP-AOA-23-iSRC and the SNAP-AOD-29, which have two isolated channels.

Transformer isolation prevents ground loop currents from flowing between field devices and causing noise that produces erroneous readings. Ground loop currents are caused when two grounded



SNAP Analog Output Modules

field devices share a connection, and the ground potential at each device is different.

Optical isolation provides 4,000 volts of transient (4,000 V for 1 ms) protection for sensitive control electronics from industrial field signals.

IMPORTANT: Since most SNAP dual-channel analog output modules provide two single-ended output channels with a common reference, these dual channels are transformer and optically isolated from other modules, but not from each other. The exceptions are the SNAP-AOA-23-iSRC and the SNAP-AOD-29, which have channel-to-channel isolation.

Part Numbers

Part	Description	See
SNAP-AOA-3	Single-channel current output, 4–20mA	pg 2
SNAP-AOV-5	Single-channel analog voltage output, 0 to 10 VDC	pg 3
SNAP-AOA-23	Dual-channel analog output, current loop, 4–20mA	pg 4
SNAP-AOA-23-iSRC SNAP-AOA-23-iSRC-FM*	Isolated dual-channel analog output, current loop, 4–20 mA, with loop sourcing	pg 5
SNAP-AOV-25	Dual-channel analog voltage output, 0 to 10 VDC	pg 6
SNAP-AOV-27	Dual-channel analog voltage output, -10 to +10 VDC	pg 7
SNAP-AOA-28	Dual-channel analog output, current loop, 0–20 mA	pg 8
SNAP-AOD-29	Dual-channel analog time-proportional digital output, 5 to 60 VDC	pg 9

* Factory Mutual approved

Dual-Channel Current Output 4–20 mA

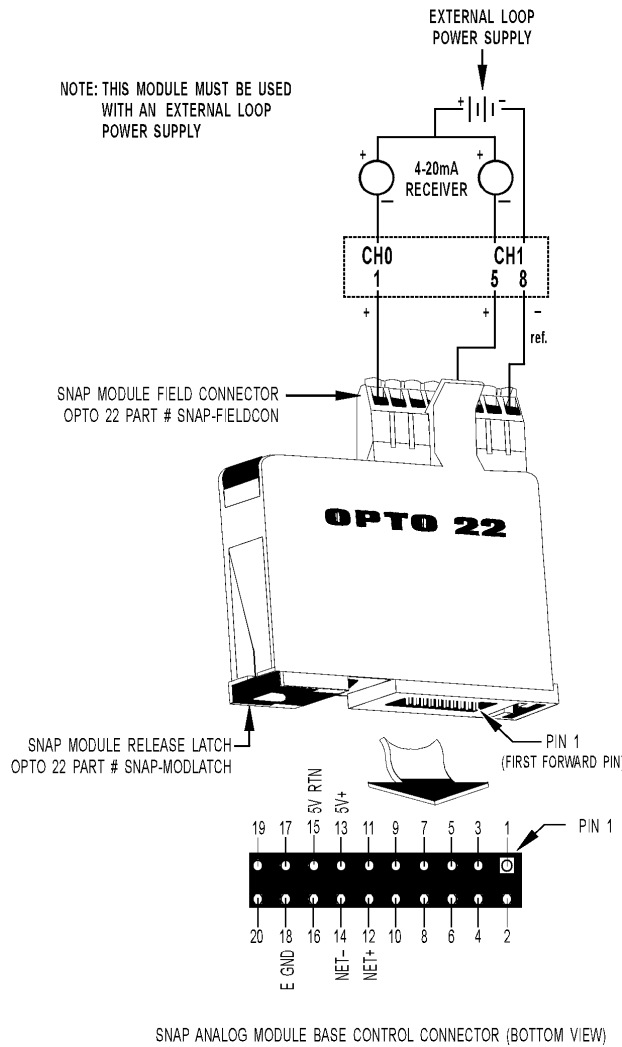

IMPORTANT: The mounting rack connector has 24 pins; the module connector has 20 pins. The extra pins on the mounting rack connector prevent misalignment of the module during installation.

SNAP Analog Output Modules

Part Number	Description
SNAP-AOA-23	Dual-channel analog output current loop 4–20 mA

Description

The SNAP-AOA-23 module provides a nominal output range of 4 mA to 20 mA. An external loop power source is required for the current loops.

NOTE: Both channels share common reference terminals. Common reference terminals are 3, 4, 7, and 8.

Specifications:

Input	12-bit serial data (each channel)										
Outputs	4 to 20 mA (each channel)										
Span	16 mA										
Resolution	3.9 microamps										
Response Time (% of span/delta I/ delta time)	99.9%/15.98 mA/3 mS										
DC Common Mode Rejection	>-120 dB										
AC Common Mode Rejection	>-120 dB @ 60 Hz										
Maximum Operating Common Mode Voltage	250 V										
Common Mode Resistance	>1000 Megohms										
Accuracy	0.1% of Span										
Gain Temperature Coefficient	50 PPM/°C										
Offset Temperature Coefficient	20 PPM/°C										
Module Power Requirements	5 Volts DC (±0.15) @ 150 mA										
Loop Power Requirements	8 VDC (min) to 32 Volts DC (max)										
Max. Loop Resistance (Ohms) @ Loop Supply	<table border="1"> <tbody> <tr> <td>250</td> <td>450</td> <td>650</td> <td>1050</td> <td>1450</td> </tr> <tr> <td>8V</td> <td>12V</td> <td>15V</td> <td>24V</td> <td>32V</td> </tr> </tbody> </table>	250	450	650	1050	1450	8V	12V	15V	24V	32V
250	450	650	1050	1450							
8V	12V	15V	24V	32V							
Max. Loop Resistance formula	$\frac{(\text{Loop Voltage} - 5)}{0.02}$										
Ambient Temperature:											
Operating	0 °C to 70 °C										
Storage	-25 °C to 85 °C										

SNAP Analog Output Modules

Dimensional Drawings

All Modules

Note: The SNAP-AOD-29 time-proportional output (TPO) module has integral LEDs for monitoring and troubleshooting the module's outputs and inhibit inputs.

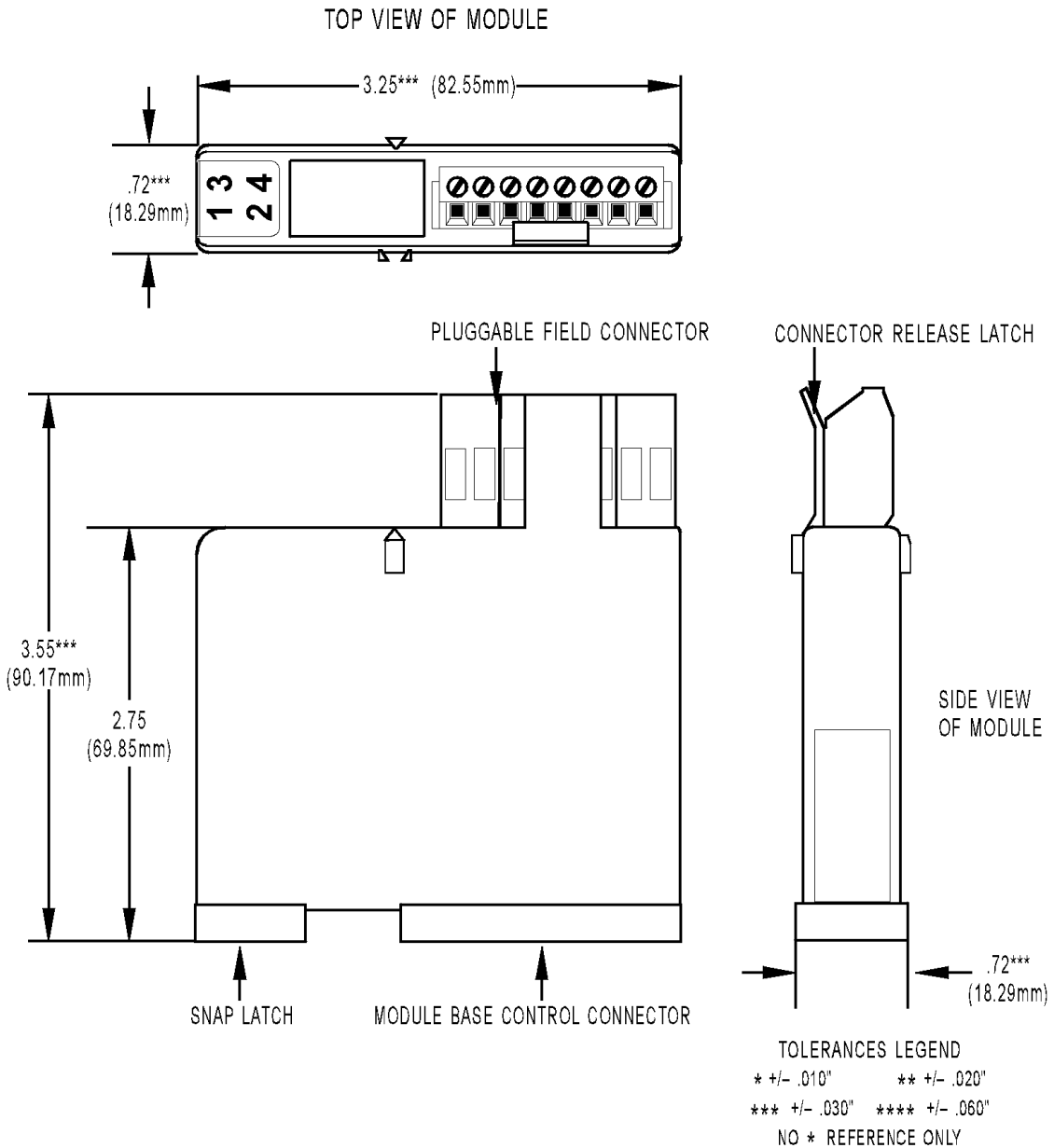

SNAP Analog Output Modules

Dimensional Drawing

All Modules

SNAP Analog Module Mounted on a SNAP Rack

